

# pro-cart



# A STRONG TYPE FOR ALL CASES

**pro-cart** is the professional choice in numerous areas of medical and laboratory technology, e.g. in

- Physiotherapy
- Endoscopy
- Ultrasound diagnostics
- Anaesthesia

**pro-cart** demonstrates its true worth when it comes to heavy loads. This is guaranteed by the design of the base, which provides stability and safety despite low space requirement, and the high load rating. Use of the entire adjustment depth means that even large items of equipment are accommodated with ease.





Application for a high-speed camera system for vocal cord analysis



ECG application

Technical data	36
----------------	----

36

Ordering data <b>pro-cart</b>	38
-------------------------------	----

38

# THE IDEAL PLATFORM FOR YOUR SOLUTIONS



The **fold-out extrusion** provides a latch to prevent unauthorized access.



The **central on and off switch** is accommodated in the cover cap to provide a hygienic cover. It is easily visible and easy to operate.



... use of **different plugs and integration of country-specific socket strips**.



The **push handle** at the rear of the support column can be adjusted to be in an ergonomic push position or a space-saving park position.



The **spacious support column** (see pages 32 / 33) offers separate routing for data lines and power cables, accommodation of residual cable volume, and ...



**Flexible rubber lips** along the support column offer short connection lines. This permits fast wipe cleaning and increases hygiene.

**pro-cart impressive in every detail**

**Perfection functionality**

- The aluminium design offers a high load rating for loads up to 80 kg / 176 lbs despite low weight.
- The shape of the base guarantees a high level of stability and optimum, space-saving integration of an isolating transformer.
- The drawer is equipped with a mechanical one-hand lock.
- The fold-out cover extrusion
  - ➔ guarantees easy access for service or assembly operations and
  - ➔ the latch option means that the cover extrusion also acts as a plug removal barrier.

**Safe power supply**

- The central on and off switch is accommodated in the cap of the support column to provide protection.
- Standard socket strips, e.g. hospital grade, can be accommodated in the support column without losing any socket spaces.

**Smart cable management**

- The spacious support column offers separate accommodation and structured cable routing of data lines and power cables.
- Rubber lips permit cable entry and exit over the entire height of the support column.

**Consistent ergonomics**

- The handle at the rear of the support column offers two positions:
  - ➔ Sliding position at 90° angle for adequate freedom of leg movement.
  - ➔ The space-saving park position at a 15° angle.



# IMPRESSIVE WITH SPACIOUS SUPPORT COLUMN

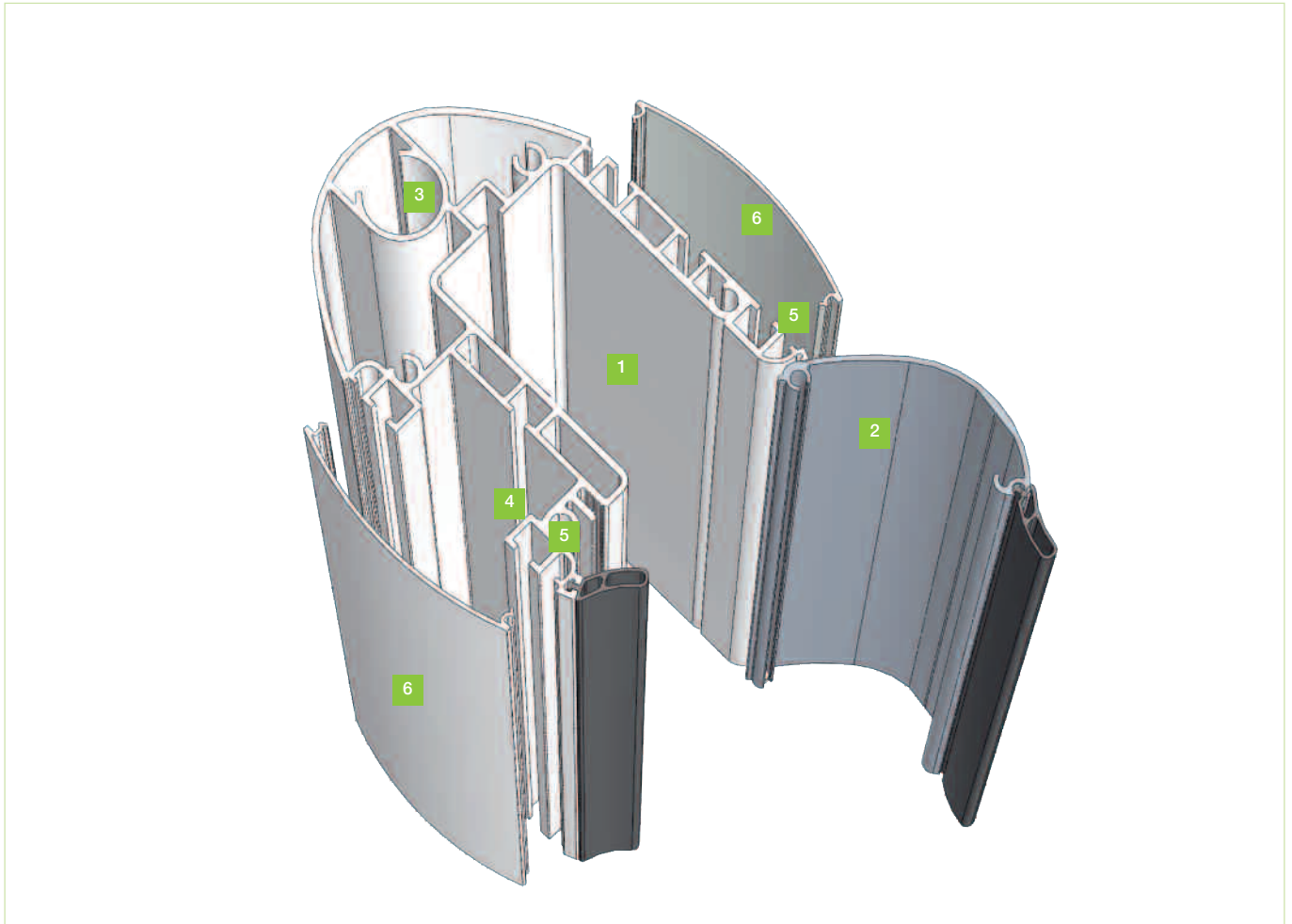

Cross-section: the open **pro-cart** support column

The newly designed support column is an outstanding innovation in the single-column **pro-cart** equipment cart. The characteristics of this innovation can be summarized in the following features:

**1** A **central, spacious centre** shaft accommodates socket strips of different dimensions (e.g. US Hospital Grade) and also offers space for outgoing cables and residual cable volumes.

**2** The **fold-out cover extrusion** with rubber lips permits cable entry and exit at any point along the support column. The semicircular cover facilitates access to power supply (e.g. socket strips). The latch option means that the cover extrusion also acts as a plug removal barrier.

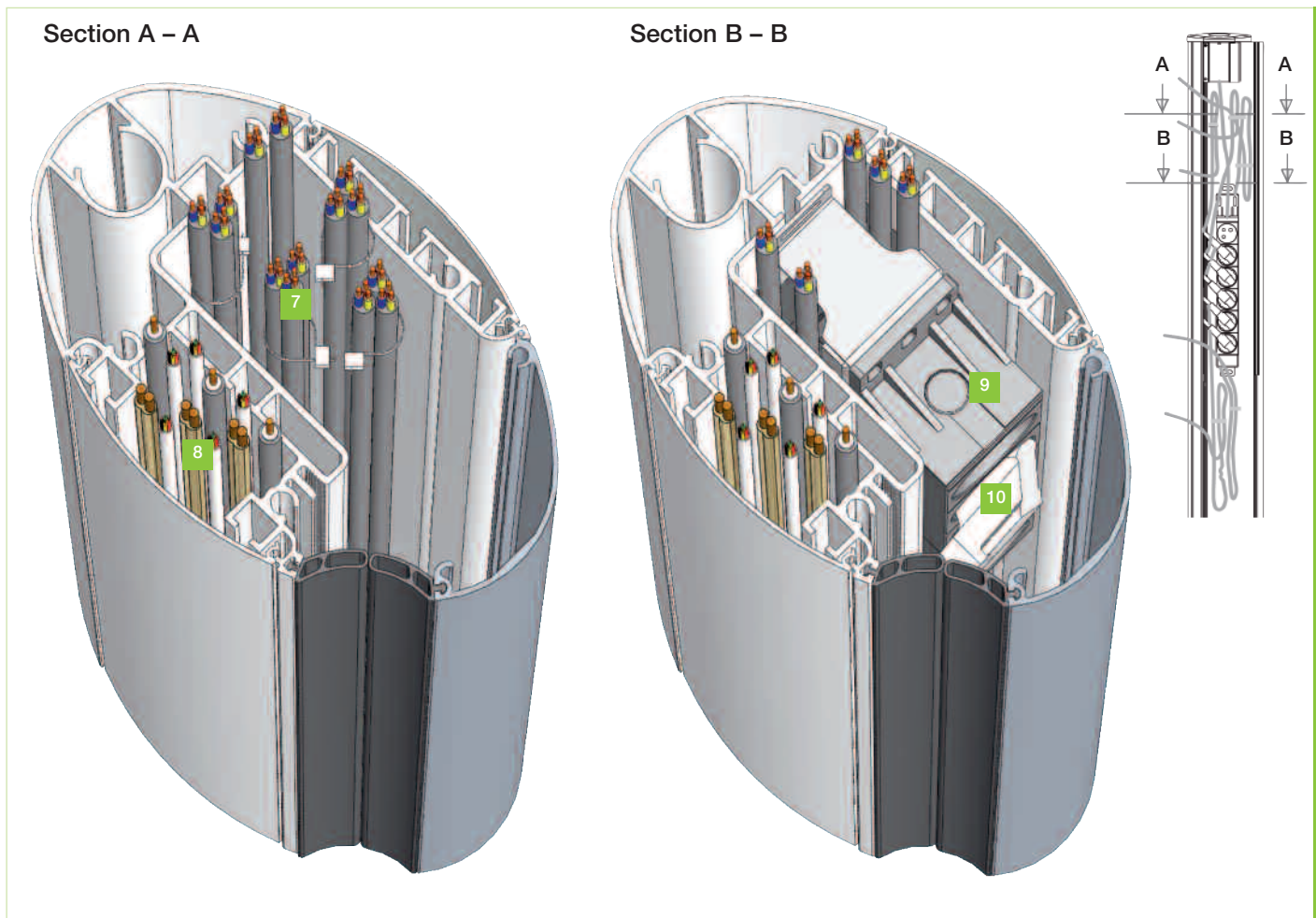

Cross section: the **pro-cart** support column with fitting

- 3 **Accessories**, e.g. infusion stand or endoscope holder, can be accommodated separately.
- 4 The **spacious cable shaft** permits structured routing of data lines.
- 5 **The two T-slots with tapped strips** (32 mm increments) on the front and rear side of the extrusion offers the option of mounting system components.
- 6 The **cover strips** close off unused extension areas.
- 7 Extended cables can be accommodated easily without any problems.
- 8 Power cables and data lines can be routed separately from residual cable volumes.
- 9 All standard socket strips can be adequately accommodated in the central shaft.
- 10 Plugs (with outgoing cables) are protected against unauthorized access by the lockable cover extrusion.



# THE MODULAR SYSTEM FOR INDIVIDUAL SOLUTIONS

The modular structure is the defining feature of the entire ITD product range. It allows all support systems to be configured, upgraded or modified for specialist functions and application areas. This capability allows users to react fast and consistently to any changes or new customer requirements.

The display presented alongside shows a small selection of system components and accessories for the **pro-cart** equipment carts. The entire accessories range with extensive descriptions and ordering information is presented in a user-friendly format from page 94.



The **block of drawers** is provided with a **mechanical one-hand lock** and this prevents unauthorized access.

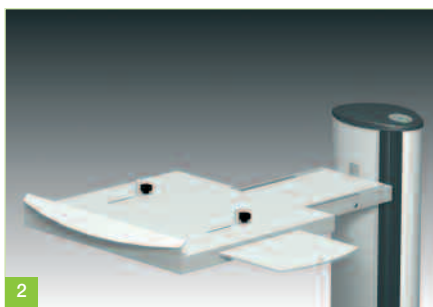

The **keyboard drawer** has a low installation height and two adjustable bars prevent the keyboard from sliding about.





3

An infusion stand with one-hand adjustment can easily be integrated in the **support column**.



4

The **swivel and tilt monitor holder** is designed for monitors with VESA 75 / 100 adaptor and up to a maximum of 14 kg / 30.8 lbs, depending on the version.



5

The **isolating transformer** – for reduction of earth-leakage currents from equipment – can be integrated in the basic frame to save space.

For an overview of system components and accessories, see page

44

# DESIGN ELEMENTS AND DIMENSIONS

- 1** Cap made of plastic (ABS), optionally with transparent cover for operating the central on/off switch, in RAL 7043 Traffic Grey B
- 2** Cover strips made of soft plastic in RAL 7043 Traffic Grey B
- 3** Central on and off switch with switch cover
- 4** Push handle (made of cast aluminium / sheet steel)
- 5** Cover extrusion (made of extruded aluminium), in RAL 7035 Light Grey, powder-coated
- 6** Vertical extrusion (made of extruded aluminium), in RAL 7035 Light Grey, powder-coated
- 7** Tapped strip (made of steel) for mounting all system components (tapped holes M6 in increments of 32 mm)
- 8** Cover strip (made of plastic) for closing the cavity of the support column between the system elements, in RAL 7035 Light Grey
- 9** Socket strip for assembly in the vertical extrusion
- 10** Base (made of aluminium), in RAL 7035 Light Grey, powder-coated
- 11** Twin swivel castors with Ø 100 mm or Ø 125 mm, 2 with wheel lock, optionally also supplied in conductive version.
- 12** Isolating transformer with 660 VA or 1200 VA and electronic inrush current
- 13** Basic trim made of plastic (ABS), in RAL 7043 Traffic grey B

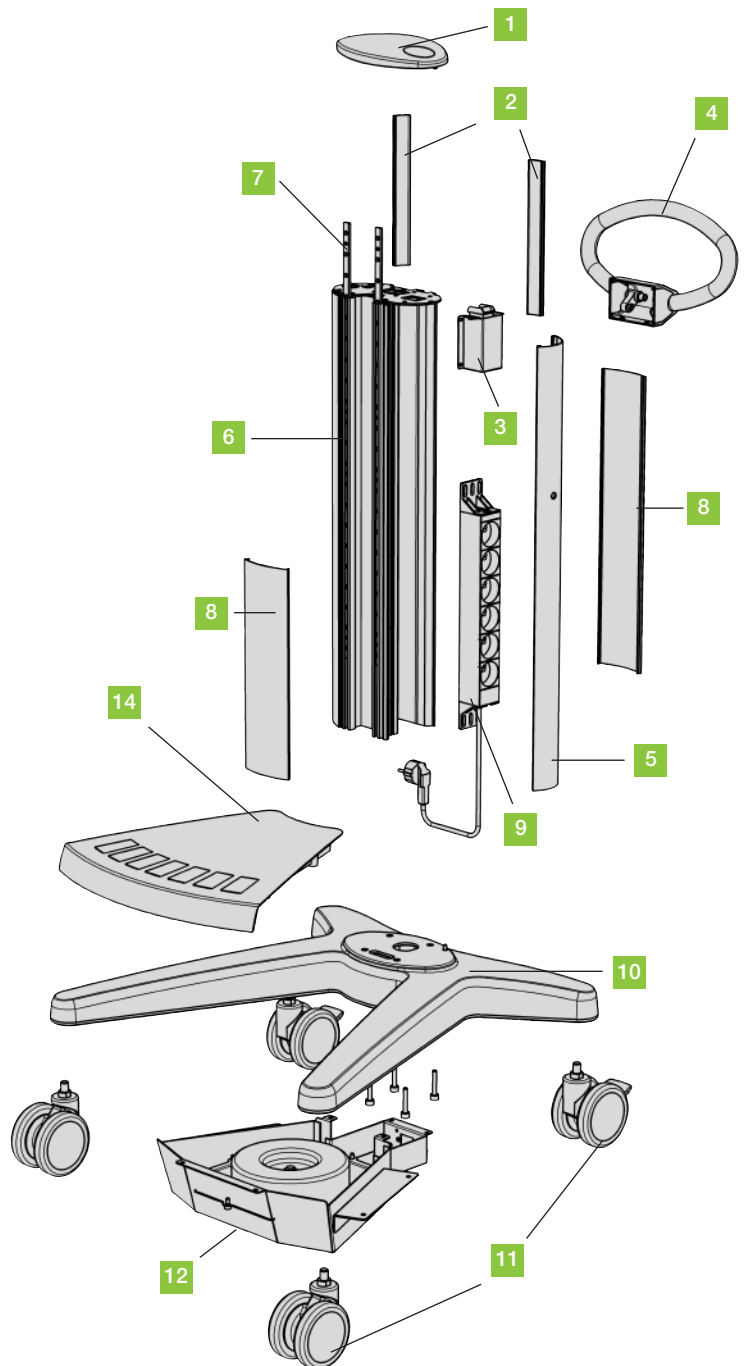

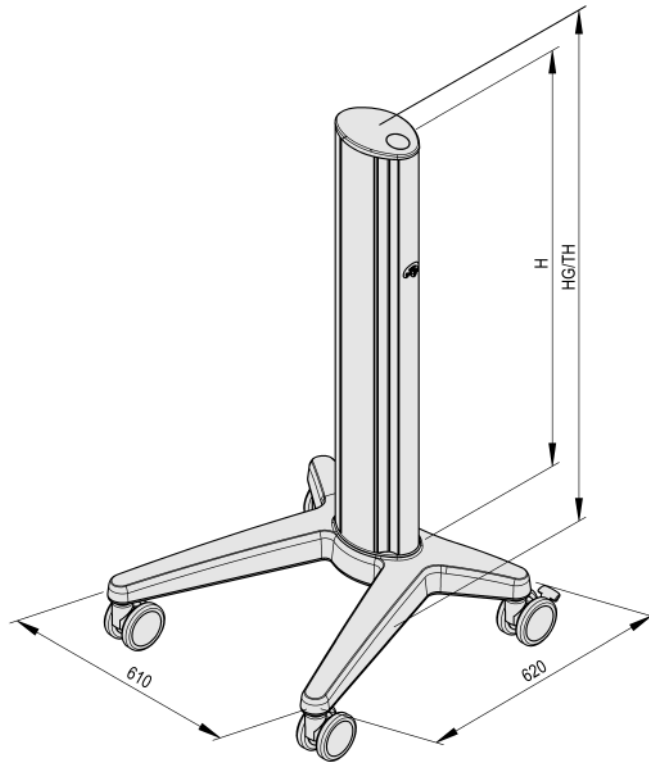

Installation height H	Length of the extrusion H	TH for Castors Ø 100 mm	TH for Castors Ø 125 mm
21 U <sup>1)</sup>	672 mm	884 mm	909 mm
30 U <sup>1)</sup>	960 mm	1172 mm	1197 mm
35 U <sup>1)</sup>	1120 mm	1332 mm	1357 mm

### Load capacity

■ Basic frame total load	80 kg / 176.0 lbs
■ Shelf	20 kg / 44.0 lbs
■ Block of drawers	
Shelf	15 kg / 33.0 lbs
Drawer	3 kg / 6.6 lbs

### Setup

- 1 Base
- 4 twin swivel castors with Ø 100 mm or Ø 125 mm, two with wheel locks. All sizes can also be supplied in conductive version.
- 1 support column with 2 tapped strips (32 mm increments) over the entire installation height
- Supplied fully assembled

<sup>1)</sup> 1 U = 32 mm

# ORDER CONFIGURATIONS



## pro-cart equipment cart, 21 U<sup>1)</sup>

Order number: PT.5000.XXX<sup>2)</sup>

Basic frame 21 U<sup>1)</sup> fitted with:

- 4 twin swivel castors Ø 100 mm, 2 with wheel locks
- 1 shelf with handle, W 450 mm, D 360 mm<sup>3)</sup>
- 1 shelf, W 450 mm, D 360 mm<sup>3)</sup>

**Load capacity:** 80 kg / 176 lbs

**Finish:**

- RAL 7035 Light Grey powder-coated
- **Trim colour and handles** see optionally <sup>2)</sup>

## pro-cart equipment cart, 21 U<sup>1)</sup>

Order number: PT.5001.XXX<sup>2)</sup>

Basic frame 21 U<sup>1)</sup> fitted with:

- 4 twin swivel castors Ø 100 mm, 2 with wheel locks
- 1 block of drawers, W 450 mm, D 360 mm<sup>3)</sup>
- 1 shelf, W 450 mm, D 360 mm<sup>3)</sup>
- 1 push handle
- 1 gel bottle holder right

**Load capacity:** 80 kg / 176 lbs

**Finish:**

- RAL 7035 Light Grey powder-coated
- **Trim colour and handles** see optionally <sup>2)</sup>

<sup>1)</sup> 1 U = 32 mm

<sup>2)</sup> **Trim colour:** Make sure you replace .XXX with .903 = RAL 7035 Light Grey, .908 = RAL 5015 Sky Blue, .909 = RAL 1003 Signal Yellow

<sup>3)</sup> = useful installation depth at 450 mm width

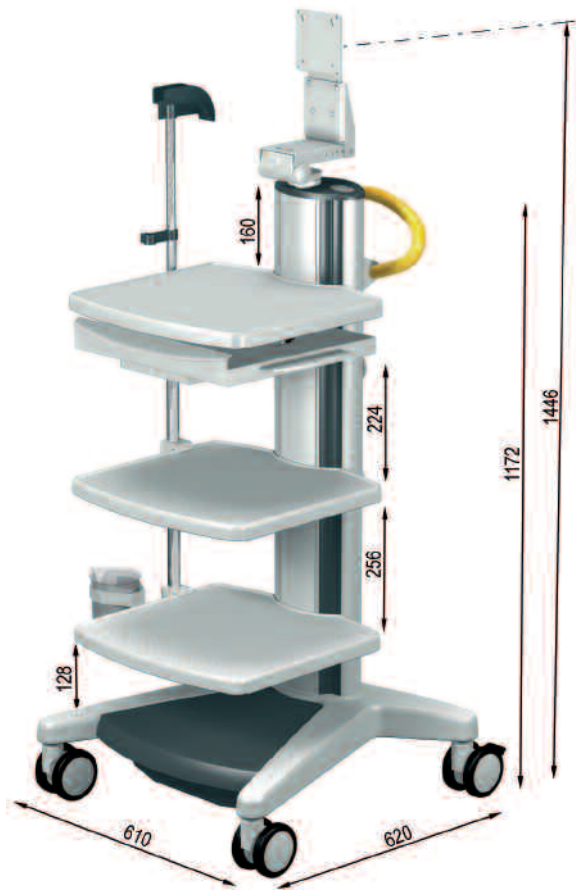

**pro-cart video cart, 30 U<sup>1)</sup> with isolating transformer**

**Order number:** VT.4300.XXX<sup>2)</sup>

Basic frame 30 U<sup>1)</sup> fitted with:

- 4 twin swivel castors Ø 100 mm, conductive, 2 with wheel locks
- 3 shelves, W 450 mm, D 360 mm<sup>3)</sup>
- 1 keyboard drawer with mousepad W 400 mm, pullout length 260 mm
- 1 swivel and tilt monitor holder for VESA 75 / VESA 100 to 14 kg / 30,8 lbs
- 1 endoscope holder with clamp
- 1 drain glass
- 1 isolating transformer 1200 VA
- 1 central on/off switch
- 1 socket strip 6-way IEC 320 with 7 equipotential bonding connectors
- 1 cable winder
- 1 push handle

**Load capacity:** 80 kg / 176 lbs

**Finish:**

- RAL 7035 Light Grey powder-coated
- **Trim colour** and **handles** see optionally <sup>2)</sup>

**pro-cart video cart, 30 U<sup>1)</sup> with isolating transformer**

**Order number:** VT.4301.XXX<sup>2)</sup>

Basic frame 30 U<sup>1)</sup> fitted with:

- 4 twin swivel castors Ø 100 mm, conductive, 2 with wheel locks
- 1 shelf with handle, W 450 mm, D 360 mm<sup>3)</sup>
- 1 keyboard drawer with mousepad W 400 mm, pullout length 260 mm
- 1 shelf, W 450 mm, D 360 mm<sup>3)</sup>
- 1 drawer, W 450 mm, D 360 mm<sup>3)</sup>
- 1 swivel and tilt monitor holder for VESA 75 / VESA 100 to 14 kg / 30,8 lbs
- 1 isolating transformer 1200 VA
- 1 central on/off switch
- 1 socket strip 6-way IEC 320 with 7 equipotential bonding connectors
- 1 cable winder
- 1 push handle

**Load capacity:** 80 kg / 176 lbs

**Finish:**

- RAL 7035 Light Grey powder-coated
- **Trim colour** and **handles** see optionally <sup>2)</sup>

<sup>1)</sup> 1 U = 32 mm

<sup>2)</sup> **Trim colour:** Make sure you replace .XXX with .903 = RAL 7035 Light Grey, .908 = RAL 5015 Sky Blue, .909 = RAL 1003 Signal Yellow

<sup>3)</sup> = useful installation depth at 450 mm width

# ORDER CONFIGURATIONS

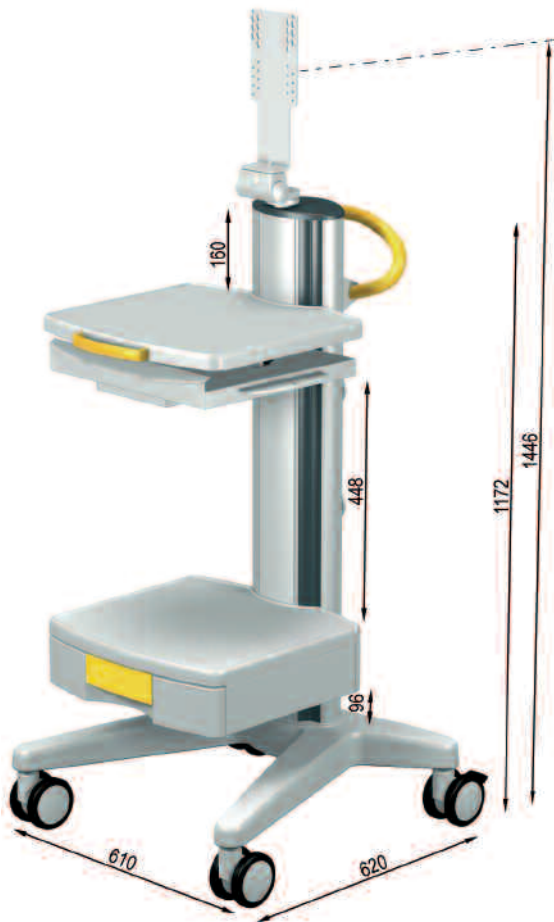

## pro-cart PC Cart, 30 U<sup>1)</sup>

Order number: PT.5004.XXX<sup>2)</sup>

Basic frame 30 U<sup>1)</sup> fitted with:

- 4 twin swivel castors Ø 100 mm, 2 with wheel locks
- 1 shelf with handle, W 450 mm, D 360 mm<sup>3)</sup>
- 1 keyboard drawer with mousepad W 450 mm, pullout length 260 mm
- 1 block of drawers, W 400 mm, D 360 mm<sup>3)</sup>
- 1 swivel and tilt monitor holder VESA 75 / VESA 100 for monitors up to 14 kg / 30,8 lbs
- 1 cable winder
- 1 push handle

**Load capacity:** 80 kg / 176 lbs

**Finish:**

- RAL 7035 Light Grey powder-coated
- **Trim colour** and **handles** see optionally <sup>2)</sup>

## pro-cart PC Cart, 30 U<sup>1)</sup> with isolating transformer

Order number: VT.4302.XXX<sup>2)</sup>

Basic frame 30 U<sup>1)</sup> fitted with:

- 4 twin swivel castors Ø 100 mm, conductive, 2 with wheel locks
- 1 shelf with handle, W 450 mm, D 360 mm<sup>3)</sup>
- 1 keyboard drawer with mousepad W 400 mm, pullout length 260 mm
- 1 block of drawers, W 450 mm, D 360 mm<sup>3)</sup>
- 1 twin monitor holder for 2 flat screens VESA 75 / VESA 100 up to each 14 kg / 30,8 lbs
- 1 isolating transformer 660 VA
- 1 central on/off switch
- 1 cable winder
- 1 socket strip 4-way IEC 320 with 5 equipotential bonding connectors
- 1 push handle

**Load capacity:** 80 kg / 176 lbs

**Finish:**

- RAL 7035 Light Grey powder-coated
- **Trim colour** and **handles** see optionally <sup>2)</sup>

<sup>1)</sup> 1 U = 32 mm

<sup>2)</sup> **Trim colour:** Make sure you replace .XXX with .903 = RAL 7035 Light Grey, .908 = RAL 5015 Sky Blue, .909 = RAL 1003 Signal Yellow

<sup>3)</sup> = useful installation depth at 450 mm width



**pro-cart ECG Cart, 30 U<sup>1)</sup>**

**Order number:** PT.5006.XXX<sup>2)</sup>

Basic frame 30 U<sup>1)</sup> fitted with:

- 4 twin swivel castors Ø 100 mm, 2 with wheel locks
- 2 shelves, W 450 mm, D 360 mm<sup>3)</sup>
- 1 keyboard drawer with mousepad W 400 mm, pullout length 260 mm
- 1 swivel and tilt monitor holder VESA 75 / VESA 100 for monitors up to 14 kg / 30,8 lbs
- 1 cable winder
- 1 push handle
- 1 holder for suction system Strässle DT 100  
See page 148 for additional holders for suction systems.

**Load capacity:** 80 kg / 176 lbs

**Finish:**

- RAL 7035 Light Grey powder-coated
- **Trim colour** and **handles** see optionally <sup>2)</sup>

**pro-cart Laptop Cart, 30 U<sup>1)</sup>**

**Order number:** PT.5007.XXX<sup>2)</sup>

Basic frame 30 U<sup>1)</sup> fitted with:

- 4 twin swivel castors Ø 100 mm, 2 with wheel locks
- 1 laptop holder (for all standard laptops)
- 1 block of drawers, W 450 mm, D 360 mm<sup>3)</sup>
- 1 push handle

**Load capacity:** 80 kg / 176 lbs

**Finish:**

- RAL 7035 Light Grey powder-coated
- **Trim colour** and **handles** see optionally <sup>2)</sup>

<sup>1)</sup> 1 U = 32 mm

<sup>2)</sup> **Trim colour:** Make sure you replace .XXX with .903 = RAL 7035 Light Grey, .908 = RAL 5015 Sky Blue, .909 = RAL 1003 Signal Yellow

<sup>3)</sup> = useful installation depth at 450 mm width



# ORDER CONFIGURATIONS



## pro-cart Mobile Computing with power height adjustment, 35 U<sup>1)</sup>

Order number: MC.1000.XXX<sup>2)</sup>

Basic frame 35 U<sup>1)</sup> fitted with:

- 4 twin swivel castors Ø 125 mm, 2 with wheel locks
- 1 power height adjuster
- 1 shelf (width 450 mm, depth 430 mm), with operator panel for the power height adjuster with display of loading status, dc/ac current and handles mounted on the side
- 1 monitor mounting VESA 75 / VESA 100 to 14 kg / 30.8 lbs monitor weight
- 1 keyboard drawer with pullout mousepad right / left
- 1 push handle
- 1 battery 55 A/h
- 1 supply/loading unit

Characteristics of supply/loading unit:

- Voltage supply of up to 4 units, adjustable from 12 V to 24 V
- Completely enclosed and maintenance-free Battery housing
- Rechargeable battery with a power of 12 V and 55 A/h
- Run-time of approx. 10 h
- Input voltage: AC 110 V / 230 V, 50 Hz / 60 Hz
- Output voltages: DC 12 V to 24 V

**Load capacity:** 80 kg / 176 lbs

**Finish:**

- RAL 7035 Light Grey powder-coated
- **Trim colour** and **handles** see optionally <sup>2)</sup>

<sup>1)</sup> 1 U = 32 mm

<sup>2)</sup> **Trim colour:** Make sure you replace .XXX with .903 = RAL 7035 Light Grey, .908 = RAL 5015 Sky Blue, .909 = RAL 1003 Signal Yellow



**pro-cart Mobile Computing, 35 U<sup>1)</sup>**

**Order number:** MC.1002.XXX<sup>2)</sup>

Basic frame 35 U<sup>1)</sup> fitted with:

- 4 twin swivel castors Ø 125 mm, 2 with wheel locks
- 1 shelf (width 450 mm, depth 430 mm), with operator panel for the power height adjuster with display of loading status, dc/ac voltage and handles mounted on the side
- 1 monitor mounting VESA 75 / VESA 100 to 14 kg / 30.8 lbs monitor weight
- 1 keyboard drawer with pullout mousepad right / left
- 1 push handle
- 1 battery 55 A/h
- 1 supply/loading unit

**Characteristics of supply/loading unit:**

- Voltage supply of up to 4 units, adjustable from 12 V to 24 V
- Completely enclosed and maintenance-free Battery housing
- Rechargeable battery with a power of 12 V and 55 A/h
- Run-time of approx. 10 h
- Input voltage: AC 110 V / 230 V, 50 Hz / 60 Hz
- Output voltages: DC 12 V to 24 V

**Load capacity:** 80 kg / 176 lbs

**Finish:**

- RAL 7035 Light Grey powder-coated
- **Trim colour** and **handles** see optionally <sup>2)</sup>

<sup>1)</sup> 1 U = 32 mm

<sup>2)</sup> **Trim colour:** Make sure you replace .XXX with .903 = RAL 7035 Light Grey, .908 = RAL 5015 Sky Blue, .909 = RAL 1003 Signal Yellow

# OVERVIEW

## SYSTEM COMPONENTS AND ACCESSORIES

<b>Basic frames</b>		21 U: <b>PT.4000.991</b> 30 U: <b>PT.4001.991</b> 35 U: <b>PT.4002.991</b>
<b>Castor conversion kit</b>	Ø 100 mm, instead of standard Ø 100 mm	<b>ZV.9428.999</b>
	Ø 125 mm instead of standard Ø 100 mm	<b>ZV.9423.999</b>
	Ø 125 mm instead of standard Ø 100 mm conductive	<b>ZV.9429.999</b>
<b>Shelf</b>	without handle	<b>PT.4100.991</b>
	with handle	<b>PT.4101.XXX<sup>1)</sup></b>
	with mousepad	<b>PT.4102.991</b>
	with handle and mousepad	<b>PT.4103.XXX<sup>1)</sup></b>
<b>Universal shelf</b>	W 450 mm x D 360 mm	<b>PT.4111.991</b>
<b>Keyboard shelf</b>		<b>PT.4108.991</b>
<b>Computer holder</b>		<b>TS.6144.991</b>
<b>Universal monitor holder</b>	for monitor up to 14 kg / 30.8 lbs	single <b>PT.4118.991</b> double <b>PT.4116.991</b>
<b>Monitor holder</b>	for monitor up to 14 kg / 30.8 lbs	single <b>PT.4119.991</b> double <b>PT.4117.991</b>
<b>Block of drawers</b>	without handle on shelf	<b>PT.4104.XXX<sup>1)</sup></b>
	without handle on shelf	<b>PT.4105.XXX<sup>1)</sup></b>
	without mousepad with handle on shelf	<b>PT.4106.XXX<sup>1)</sup></b>
	with mousepad with handle on shelf	<b>PT.4107.XXX<sup>1)</sup></b>
<b>Block of drawers, high</b>	1 unit, without handle on shelf	<b>PT.4113.XXX<sup>1)</sup></b>
	1 unit, with handle on shelf	<b>PT.4114.XXX<sup>1)</sup></b>
<b>Basket</b>	assembly in the front T-slots	<b>ZV.9967.800</b>
<b>Camera holder</b>	with clamp	<b>GW.9983.991</b>
<b>Gel bottle holder</b>	einfach	<b>GW.0800.991</b>
<b>Gas bottle holders</b>	for gas bottles with max. 2 l content	<b>GW.0466.991</b>
<b>Infusion stand</b>	4-arm with one hand - adjustment	<b>PT.2006.999</b>
<b>Standard runner</b>	Length 162 mm	<b>RS.0132.991</b>
	Length 390 mm	<b>RS.0076.991</b>
<b>Anchor</b>		<b>ZV.9820.799</b>
<b>Clamp</b>	for shelf	<b>ZV.9878.999</b>
	for standard runner	<b>ZV.9876.999</b>
<b>Holder for suction system</b>	Strässle /Ergoline	<b>PT.2009.991</b>
	Hellige / KISS	<b>PT.2010.991</b>
	Ohlenschläger	<b>PT.2011.991</b>
<b>Foot switch cradle</b>		<b>ZV.9991.991</b>

<sup>2)</sup> **Trim colour:** Make sure you replace .XXX with .903 = RAL 7035 Light Grey, .908 = RAL 5015 Sky Blue, .909 = RAL 1003 Signal Yellow

Holder for transducer		PT.2005.991
Box holder „Dracula“		ZV.9832.999
Pivot arm	single, with VESA 75 adaptation for flat screen	TS.6314.991
	double, with VESA 75 adaptation for flat screen	TS.6315.991
Variable height arm	length 400 mm, with VESA 75 adaptation for flat screen	ZV.9538.999
Jointed arm	with hose clamps, for cable management	ZV.9955.799
Handle		PT.2000.XXX <sup>1)</sup>
Socket strips EURO	6-way	ZV.9433.999
	6-way, with central on / off switch	ZV.9432.999
Socket strips	8-way earthed, with central on / off switch	ZV.9434.999
	6-way, French standard	ZV.9441.999
	6-way, French standard with central on / off switch	ZV.9440.999
Cable winder		PT.2004.991
Isolating transformer	660 VA	ZV 9446.999
	1200 VA	ZV 9447.999
Insulation monitor ELG		PT.2008.991

<sup>2)</sup> **Trim colour:** Make sure you replace .XXX with .903 = RAL 7035 Light Grey, .908 = RAL 5015 Sky Blue, .909 = RAL 1003 Signal Yellow

You will find a comprehensive description and ordering information on all components suitable for **pro-cart** in the **system components and accessories** section.

<b>System components and accessories</b>	<b>from page</b>	94
<b>Order number index</b>	<b>from page</b>	180